

SAFETY GUIDELINES

Please read this entire manual before using this device, paying extra attention to these safety warnings and guidelines. Please keep this manual in a safe place for future reference.

- Do not exceed the rated weight limit. Doing so can cause the mount to fail, resulting in equipment damage and/or severe personal injury.
- Ensure that the structure to which this mount will be installed is capable of supporting at least four times the total weight of the mount and any connected displays.
- Use the supplied mounting screws. Tighten the screws using the appropriate tool, but take care not to over-tighten them.
- This device is intended for indoor use only.
- This device contains small parts that could pose a choking hazard to small children. Keep this device and its spare parts out of reach of children.
- Inspect the installation at least once every three months to ensure that it is secure and safe to use.
- Please take an inventory of the package contents to ensure you have all the items shown in the Parts List. If anything is missing or damaged, please contact Monoprice Customer Service for a replacement.
- This appliance can be used by children aged from 8 years and above if they have been given supervision or instruction concerning use of the appliance in a safe way and understand the hazards involved. Children shall not play with the appliance. Cleaning and user maintenance shall not be made by children without supervision.
- Persons with reduced physical, sensory or mental capabilities or lack of experience and knowledge must not use the appliance, unless they're under supervision, understand the hazards involved or they have been thoroughly instructed in the use of the apparatus by a person who is responsible for the safety of these persons.
- Don't leave the cords or plug unorganized in order to prevent tripping hazards.
- Any attempts to reconstruct the construction aren't allowed.
- The appliance is only to be used with the power supply unit provided with the appliance. Alterations of the given power unit aren't allowed.
- Never operate the system with a damaged power supply cord or plug. If any parts is damaged, please contact your service agent of purchase for a replacement.
- Never operate the system if it's in moist environment or its electrical components has contact with liquids.
- Don't clean the product while the power is still connected.
- Don't disassemble or replace components while the power is still connected.
- Unplug the appliance when the system isn't in use, and place the power plug out of children reach.

CUSTOMER SERVICE

The Monoprice Customer Service department is dedicated to ensuring that your ordering, purchasing, and delivery experience is second to none. If you have any problem with your order, please give us an opportunity to make it right. You can contact a Monoprice Customer Service representative through the Live Chat link on our website www.monoprice.com or via email at support@monoprice.com. Check the website for support times and links.

Commercial Series

**Motorized TV Lift Stand for TVs between 37in to 65in,
Max Weight 110lbs, VESA Capability up to 600x400**

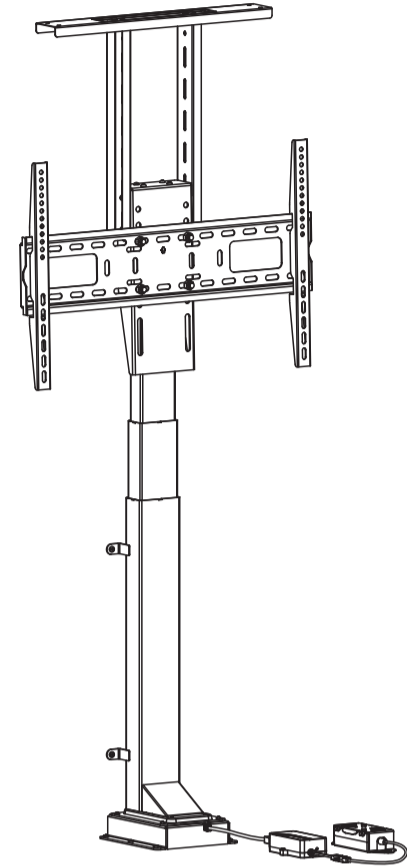

P/N 39659



200x200/300x300
400x200/400x400
600x400



REMOTE CONTROL OPERATION INSTRUCTIONS

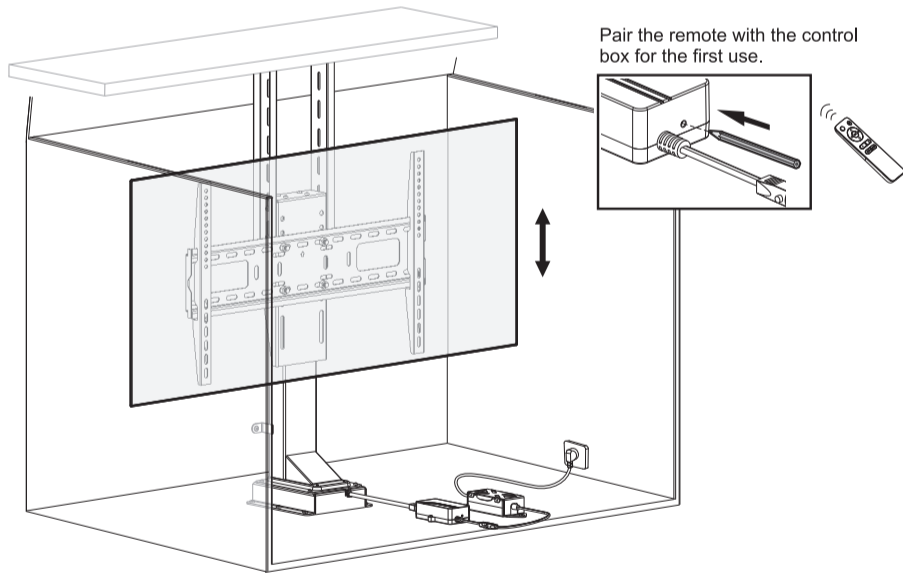

Pair the remote with the control box for the first use.

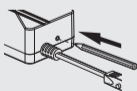

REMOTE CONTROL OPERATION INSTRUCTIONS

Remote Requires 2 AAA batteries (Not Included)

A. Coding of Remote Control and Control Box

Step 1: When the mount is powered on, press the small button on the control box with a thin tool as shown. The unit will emit a beep, indicating that the control box is on standby for program coding.

Step 2: Press the "SET" button on the remote, and you will hear repeated beeps for approximate 10 seconds indicating that the remote control is being programmed. The unit will emit a beep again indicating success.

B. Button Functions

1. Upward/Downward Movement

Press and hold the 'Δ' button to lift the mount. Press and hold the '▽' button to lower the mount. Make sure to clear all obstacles within the range of motion.

2. Memory Setting

Long press the "mem1" or "mem2" button for 3 seconds until you hear a beep, indicating that the current position has been saved to memory. The "mem1" and "mem2" buttons can each store a different position.

3. Recall Memory

Press the "1" or "2" buttons and the mount will automatically return to the position saved to the corresponding button. "1" is preset to the highest position and "2" is preset to the lowest.

4. Default Setting

Short press the "OK" button and the mount will automatically retract to the lowest position. To stop it, press the "OK" button again.

5. Reset Mode

Long press the "OK" button for 3 seconds until you hear a beep. The mount will start to move downwards then move slightly upward. The system has reset successfully when the unit emits two beeps.



Disposal:

The product with this mark indicates that this product shouldn't be disposed with other household wastes throughout the EU. To prevent possible harm to the environment or human health from uncontrolled waste disposal, recycle it responsibly to promote the sustainable reuse of material resources. To return your used device, please use the local recycle service or contact your point of purchase to withdraw the product.

Troubleshooting Guide

This Troubleshooting Guide will assist you in identifying and solving common problems and answering questions you may have about the product. Contact your place of purchase should the answer to your question or problem not be found in this Troubleshooting Guide and/or for any after service parts and sales support.

1. Possible reasons motorized mount does not respond to remote control.

A. TV Mount

- The system may be error. Check if the unit beeps three times after pressing the button. If so, please reset the system.
- The system may be overheating. Check if the unit beeps four times after pressing the button. If so, allow the unit to cool down and return to room temperature. (about 30 minutes)
- The AC/DC end of the power cord may be unplugged/disconnect from the outlet/mount. Check the connection to ensure the unit has power.
- Incorrect operation. Check if the unit beeps once after pressing the button. If so, please follow the instructions found in the manual to properly operate the mount.

B. Remote Control

- The remote control operating distance may be too far and not in range of the mount. Acceptable range should be less than 30 feet (10m).
- The batteries in the remote control may be low or dead. Replace the batteries.
- The remote control may be broken. Check to see if the indicator LED found on the remote lights when a button is pressed. If not, contact your place of purchase for a replacement.

2. The TV mount stops moving during operation and emits a long beep.

- Check to see if a foreign object is impeding the mount from moving. If so, remove the object and discard.
- The weight of TV may exceed the maximum weight limitation of the mounting system.
- The motor wire may be broken. Reset the system. If the problem still exists, contact your place of purchase for replacement.

3. The TV mount is making an abnormal noise or sound.

- Check all power connections and reset the system. If the unit continues to make an abnormal noise, please contact your place of purchase for a replacement.

3. Clearing the Saved Data from the Remote.

Clear the saved data when replacing the remote control by pressing the small button on the control box. You will hear a single beep, hold the button for 5 seconds more to confirm the data clearing process, you will hear one more beep.

PACKAGE CONTENTS

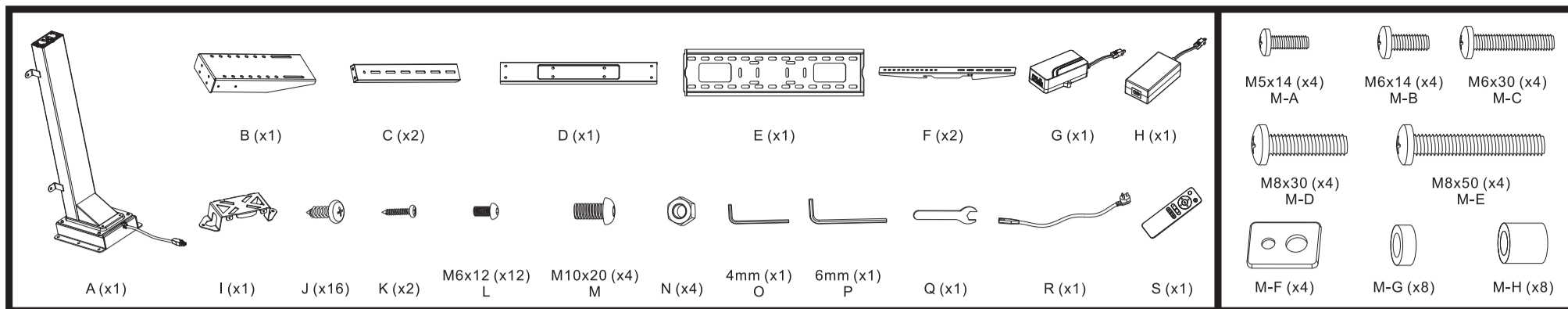

WARNING! **CABINET INSTALLATION**

Please prepare a proper cabinet before installation. Ensure there is adequate spacing for TV.

